

3. If proper alignment is not obtained with the steps above, the hammer may be bent slightly by removing it from the lock, heating it to a bright red with a torch, and bending it carefully in a vise to obtain the correct alignment.

WARNING: Never attempt to alter the position of the barrel lock bolt (drawn) on the Trapper and Kentucky barrels nor the breech plug from any Traditions pistol kit barrel. To do so would create a DANGEROUS unsafe situation as well as void the warranty.

V - Securing Barrel To Stock

A. Kentucky Pistol only:

1. Gently tap rear ramrod thimble (the larger of the two) into ramrod channel until the threaded hole in its side lines up with the hole in the barrel channel of the stock. Enlarge ramrod thimble hole in stock if needed. Insert and tighten ramrod thimble screw through stock and into thimble.
2. Line up threaded hole in front thimble with front hole in barrel channel of the stock. Insert and tighten ramrod thimble screw.

B. Trapper and Pioneer Pistol:

1. If necessary, remove wood from bottom of lock recess until lock is flush with the barrel.
2. With barrel positioned in channel and tang screw loose, insert tenon wedge through stock and tenon. Wedge should fit snugly. Stock opening can be slightly enlarged if necessary. For tighter fit, bend wedge slightly.

C. Trapper and Kentucky only:

1. With barrel in its channel, attach nutcase with two nose-cap screws. Wood should be removed only if necessary, for close fit of nosecap against barrel.
2. Tighten nutcase.

D. Trapper only:

1. Attach grip cap with grip cap screw.

F. Crockett Pistol:

Securing Barrel to stock:

1. Measure carefully and mark the exact point on stock which will place a hole through the center of the barrel tenon.
2. With barrel tightly secured in stock, drill a small perpendicular hole completely through the stock and the tenon.
3. Enlarge the hole to approximately 9/16ths inch and tap tenon pin through the hole.

VI - Trigger Guard Installation

A. Press rear spring guard into inlet in stock. Next align front of trigger guard into its position. It may be necessary to slightly lengthen the cut-out in the stock inlet or to gently bend the guard slightly.

B. Insert and tighten the two trigger guard screws.

VII - Finishing of Wood and Metal

- A. Using wood tarp, emery cloth and sandpaper, bring wood surfaces flush with metal parts.
- B. Remove metal parts to stain and finish the stock as desired.
- C. Polish brass and bare steel parts with progressively finer grades of emery cloth. Finish with fine grade steel wool.
- D. Brown or blue bare steel parts with chemicals available in most gun shops.

TRADITIONS™
PERFORMANCE MUZZLELOADING
Assembly Instructions
Percussion Pistol
Kits

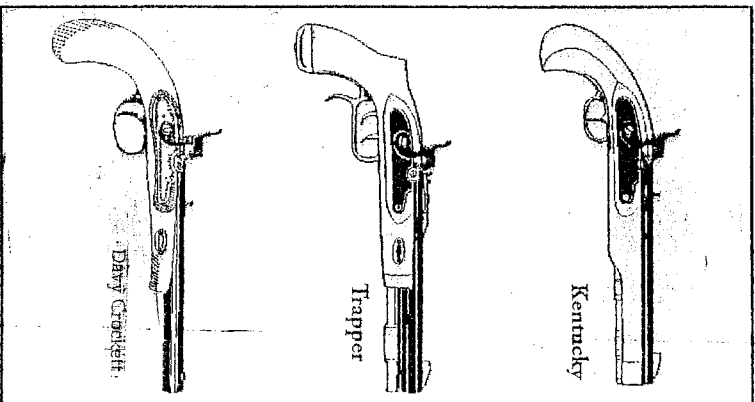

TRADITIONS PERFORMANCE MUZZLELOADING
P.O. Box 776 • 1375 Boston Post Road
Old Saybrook, CT 06475-0776
Phone: (860)-388-4656
Fax: (860)-388-4657
e-mail: trad@ct2.nai.net
www.traditionsmuzzle.com

Kentucky Pistol Kit

KP5060 .50 caliber Percussion

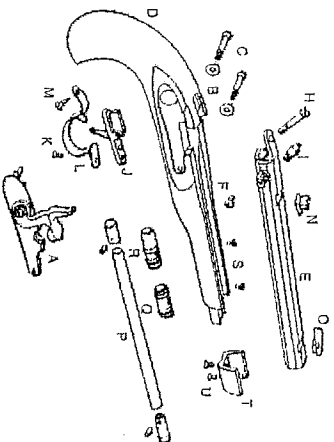

Letter	Description	Number
A	Lock - percussion	20203
B	Lock Plate Washer (2)	20619
C	Lock Plate Screw (2)	20230
D	Stock	10601
E	Barrel Assembly* .50 cal. percussion	C105020
F	Bolster Screw	20605
H	Tang Screw	10409
I	Nipple	20608
J	Trigger Assembly	20222
K	Trigger Assembly/Guard Screw	10435
L	Trigger Guard	10423
M	Trigger Guard Screw	20624
N	Rear Sight	20210
O	Front Sight	20641
P	Ramrod Assembly/Ramrod Thimbles	10628
Q	Front Thimble	10613A
R	Rear Thimble	10613B
S	Ramrod Thimble Screw (2)	20214
T	Nose Cap	10615
U	Nose Cap Screw (2)	20225

*Barrel sold only as a complete assembly. Bolster not sold separately.

Davy Crockett Pistol

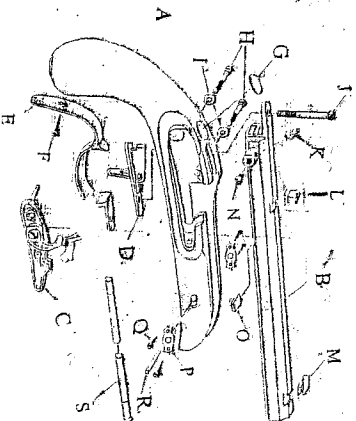

Letter	Description	Number
A	Stock (Beech) Kit	K-126521
B	Stock (Beech) finished	PCS126521
C	Barrel Assembly-Kit	
	32 cal. perc. (twist 1:48")	C136526
	Barrel Assembly Blued-finished (B)126526	
	Percussion Lock Assembly*	
	Percussion Lock Assembly†	10803
D	Trigger Guard	10423
E	Trigger Guard Screw (rear)	20624
F	Brass Inlay	26209
G	Lock Plate Screw (2)	20220
H	Lock Plate Washer (2)	20619
I	Tang Screw	10409
J	Nipple	20608
K	Trigger Guard	10423
L	Trigger Guard Screw (rear)	20624
M	Brass Inlay	26209
N	Lock Plate Screw (2)	20220
O	Lock Plate Washer (2)	20619
P	Tang Screw	10409
Q	Nipple	20608
R	Trigger Guard	10423
S	Trigger Guard Screw (rear)	20624

Pioneer Pistol Kit

KP4265 .45 caliber percussion

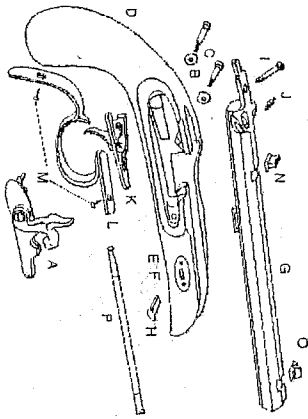

Letter	Description	Number
A	Lock Assembly - Percussion	12603
B	Lock Plate Washer (2)	20840
C	Lock Flare Washer Screw (2)	20220
D	Stock	12601
E	Stock Plate - installed (2)	21836
F	Stock Plate Screw - installed (4)	21817
G	Barrel Assembly*	C126005
H	Barrel Tenon Wedge	12618
I	Tang Screw (1 1/8" long, machine screw)	10109
J	Nipple	20608
K	Trigger Assembly	22222
L	Trigger Guard	12623
M	Trigger Assembly/Guard Screw (2)	20624
N	Rear Sight	20210
O	Front Sight	12611
P	Ramrod Assembly	12628

*Barrel assembly includes tang and barrel tenon, separately. The barrel assembly is in the white.

Percussion Lock Assembly

21603 - Pioneer Lock Assembly

Letter	Description	Number
A	Lock Plate	70601
C	Main Spring	70505
D	Sear Adjusting Screw Spring	70520
E	Sear Spring	70506
G	Sear Adjusting Screw	70518
H	Hammer Screw	75312
I	Sear Screw	70514
J	Sear Spring & Bridle Screw (2)	70515
N	Hammer	70602
R	Hammer	70503
S	Tumbler	70504
S	Sear	70504

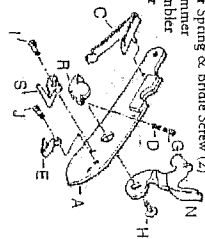

20603 - Trapper Lock Assembly

Letter	Description	Number
A	Lock Plate	70601
C	Main Spring	70505
D	Sear Adjusting Screw Spring	70520
E	Sear Spring	70506
G	Sear Adjusting Screw	70518
H	Hammer Screw	70512
I	Sear Screw	70514
J	Sear Spring & Bridle Screw (2)	70515
N	Hammer	70602
R	Hammer	70503
S	Tumbler	70504
T	Bridle	70508
U	Fly	70511

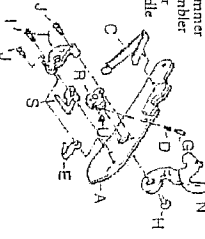

20203 - Kentucky Lock Assembly

Letter	Description	Number
A	Lock Plate	70201
C	Main Spring	70505
D	Sear Adjusting Screw Spring	70520
E	Sear Spring	70506
G	Sear Adjusting Screw	70518
H	Hammer Screw	70512
I	Sear Screw	70514
J	Sear Spring Screw	70515
N	Hammer	70521
R	Hammer	70602
S	Tumbler	70103
S	Sear	70504

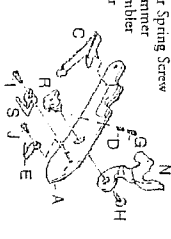

ASSEMBLY INSTRUCTIONS

You are about to build a muzzleloader which will be fairly showable. For this reason it must be handled responsibly and with the same precautions and respect due any firearm. Before loading or shooting your gun, refer to the enclosed booklet *Limited Lifetime Warranty and Shooting Instructions*. Read it completely and carefully and be willing to follow all the instructions and safety precautions at all times. **IMPORTANT!** If this companion booklet is not with this kit, contact Traditions for a free copy.

Before working on your TRADITIONS pistol kit, carefully inspect the component parts and the terms of the Limited Lifetime Warranty in the accompanying booklet. Be aware that the warranty covers only parts of this kit that have not been altered beyond reason.

The following instructions will enable a moderately handy person to build a safe, serviceable and shootable muzzleloader. Your attention to detail and patience will be rewarded with a truly fine replica muzzle-loading firearm.

Read these instructions thoroughly before beginning assembly.

Pre-Assembly Instructions

There are three stages to the building of your muzzleloading pistol. Performing each will help insure that you build the best kit you possibly can.

A. Before attempting any cutting, drilling, staining, bluing or the like, take all the major components (lock, stock, barrel, trigger, trigger guard, etc.) and roughly fit them together to get a feeling of where they go and how they relate to each other.

B. Separate and identify the parts and start the actual assembly of the gun as noted in the following instructions.
Note: Only after all the various parts are fully-installed, aligned and finally assembled and no additional alterations or sanding to the wood or metal is anticipated, should you attempt to do any staining, finishing or bluing of the wood and metal.

I - Assembly Instructions, General

A. All metal parts should fit snugly into their respective cut-out in the stock, removing a minimum of wood, only if necessary, with a sharp chisel, carving tool, or craft knife. Remove sparingly so as not to remove too much at one time.

B. To facilitate assembly and to avoid cracking the stock, small pilot holes should be drilled before inserting wood screws into the stock.

C. Turn all metal screws into and out of their respective threaded holes several times to burr the threads and improve fit.

II - Lock Installation
A. Insert lock into its cut-out in the stock.
B. Install lock into its cut-out in the stock.
C. Turn all metal screws into and out of their respective threaded holes through the stock and into their corresponding holes in the lock plate. If holes are not perfectly aligned, enlarge one or both stock holes with a round file or drill to improve alignment. Do not alter the threaded holes in the lock plate. Tighten screws into holes in lock plate. Screw should be flush with the lock plate. File off any excess. Note: For Trapper and Kentucky pistols the ramrod retaining spring must be installed at this time. Place front lock screw and washer

through the left side of the stock then through the hole in the ramrod retaining spring. Position the spring so its belly is curving downward and the flat end is towards the back of the pistol. Note: For a tighter hold on the ramrod, bend spring slightly to increase the curve. For a looser hold, flatten spring slightly to decrease the curve.

III - Barrel Assembly

A. Trapper only.

1. Assemble ramrod thimble to the center hole in the barrel rib with one thimble/barrel rib screw.

2. Install rib to the underside of the barrel using remaining two thimble/barrel rib screws.

3. Join barrel tang and barrel, filing barrel lock surfaces as needed for a flush, snug, snug fit.

B. Install dovetailed barrel tenon (Trapper) and tightens into their respective cut-outs in barrel.

C. The barrel tenon (Trapper) and dovetailed sights should fit snugly. If necessary, enlarge dovetail cut-out in barrel with a thin-spillar file or reduce them slightly by first installing the part then indicating the dovetail surface edges with a hammer and punch.

D. Trapper and Kentucky only, screw nipple and clean-out screw into barrel holster (dunn), Pioneer only, screw nipple into small.

C. Set hammer at half-cock.

E. Fit barrel (and tang assembly) into stock. The barrel holster (dunn) or nail should be centered in the excess cut-out in the lock plate. The lock plate, in turn, should be snug against the barrel.

IV - Trigger and Tang Screw Installation

A. Check that the tang screw fits smoothly into its corresponding threaded hole in the trigger plate, turning it in and out several times to burrish the threads.

B. Place trigger assembly into its stock inlet, gangily removing wood as necessary so that no moving part touches wood. For Trapper double set trigger assembly, also insure that the wire spring in front of the trigger assembly does not touch any wood.

C. Insert the tang screw into the hole in the tang, through the stock and screw it into the trigger assembly. Do not tighten tang screw at this time. Note: In the event that the tang screw needs alignment, change hole in the stock with a round file or drill.

D. Trapper only; Insert and tighten the one trigger assembly wood screw.

E. IMPORTANT SAFETY PRECAUTION. With lock, barrel and trigger assembled and all screws tightened, the lock hammer should remain securely in its half-cock position. Pulling the trigger should not cause the hammer to fall. The hammer should also remain in the full cock position until the trigger is deliberately pulled. If the lock and trigger do not function properly in both positions, remove the lock and reference the companion *Limited Lifetime Warranty and Shooting Instructions* manual for double set trigger adjustment.

F. The hammer should be positioned squarely on the nipple. If it is not, one or more of the following steps may be taken:

1. Remove wood from bottom of lock recess until lock is flush with the barrel.
2. Remove wood as needed from under and behind the barrel channel, including tang area.